



General Store Type Freezers and Fridges

UMD IZMIR Series



User Manual **EN**

UMD 1450 D DF IZMIR
UMD 1450 D IZMIR
UMD 1450 D/S DF IZMIR
UMD 1850 D DF IZMIR
UMD 1850 D IZMIR
UMD 1850 D/S DF IZMIR
UMD 1850 D/S DF VS IZMIR
UMD 1850 GB D DF IZMIR
UMD 1850 GB D IZMIR
UMD 1850 GB D/S DF IZMIR
UMD 1850 GB D/S DF VS IZMIR
UMD 1850 GB S DF VS IZMIR
UMD 2100 D DF IZMIR
UMD 2100 D DF VS IZMIR
UMD 2100 D IZMIR
UMD 2100 D/S DF IZMIR
UMD 2100 D/S DF VS IZMIR
UMD 2100 S DF VS IZMIR
UMD 2500 D DF IZMIR
UMD 2500 D DF VS IZMIR
UMD 2500 D IZMIR
UMD 2500 D/S DF IZMIR
UMD 2500 D/S DF VS IZMIR
UMD 2500 S DF VS IZMIR

İÇİNDEKİLER

1- BASIC INFORMATION	5
1.1- SYMBOLS.....	5
1.2- INTRODUCTORY PICTURES	5
1.3- PRODUCER’S AREA OF RESPONSIBILITY	6
2- SAFETY INFORMATION AND ENVIRONMENTAL WARNINGS	7
2.1- BEFORE OPERATION OF THE EQUIPMENT	7
2.2- TECHNICAL SAFETY	8
2.3- DURING OPERATION OF THE EQUIPMENT	8
2.4- WASTE DISPOSAL	9
3- INSTALLATION	10
3.1- SELECTION OF DEVICE PLACE	10
3.2- TAKING OUT OF PACKAGE	10
3.3- INSTALLATION	11
3.3.1- ADJUSTMENT OF ADJUSTABLE STAYS	11
3.3.2- MULTIPLE DEVICE USE LAY-OUT POSITIONS	11
3.3.2.1- STAND ALONE USE.....	11
3.3.2.2- SINGLE LINE ARRAY	11
3.3.2.3- SUCCESSIVE ARRAY	11
3.3.2.4- HEAD FRIDGE AND ISLAND ARRAY	12
3.4- ELECTRICAL CONNECTIONS	12
4- DEVICE USAGE	13
4.1- THERMOSTAT ADJUSTMENTS (EWPLUS 978)	13
4.1.1- GENERAL INFORMATION AND INSTRUCTIONS	13
4.1.2- SET TEMPERATURE.....	15
4.1.3- AUTOMATIC DEFROST	15
4.1.4- MANUAL DEFROST	16
4.2- THERMOSTAT ADJUSTMENTS (EWPLUS 971)	16
4.2.1- GENERAL INFORMATION AND INSTRUCTIONS	16
4.2.2- SET TEMPERATURE	17
4.3- THERMOSTAT ADJUSTMENTS (AKCC 210)	17
4.3.1- GENERAL INFORMATION AND INSTRUCTIONS	17

4.3.2- SET TEMPERATURE	18
4.3.3- MANUAL DEFROST	18
4.3.4- CUTOUT ALARM RELAY/RECEIPT ALARM/SEE ALARM CODE	18
4.4- THERMOSTAT ADJUSTMENTS	18
4.4.1- GENERAL INFORMATION AND INSTRUCTIONS	18
4.4.2- SET TEMPERATURE	18
4.4.3- MANUAL DEFROST	18
4.5- THERMOSTAT ADJUSTMENTS (ERC 112D)	19
4.5.1- GENERAL INFORMATION AND INSTRUCTIONS	19
4.5.2- GENERAL INFORMATION AND INSTRUCTIONS	19
4.5.3- MANUAL DEFROST	19
5- SPECIAL INSTRUCTIONS FOR USE	20
5.1- DEFROSTING	20
5.2- GLASS CLEANING	20
5.3- GLASS CLEANING	21
5.4- LOADING CAPACITY	21
6- TURNING OFF AND CARRYING THE DEVICE	22
6.1- TURNING OFF THE DEVICE	22
6.2- CARRYING THE DEVICE	22
7- TURNING OFF AND CARRYING THE DEVICE	23

Dear Valued Customer,

The device you have bought is manufactured by taking quality as priority and designed in order to provide you the best performance.

We advise you to read the explanations offered in this guide carefully and to act in accordance with the stated rules before installation of the device and before using the device in order to ensure the best performance. In case you do not comply with the explanations stated in this guide, you will go beyond the scope of your warranty in case of any malfunction of the device.

Please keep this guide to use in the application transactions that you may need to make later.

1- BASIC INFORMATION

1.1- SYMBOLS

Some significant points in using the device are made attention grabbing with symbols. The meaning of these symbols are stated below in accordance with their prioritization order. Please pay attention to these symbols.



WARNING

It involves information provided in order to prevent serious damages that may result in injuries, loss of life and property during use.



NOTE

It involves the information regarding what to pay attention during use.



SUGGESTION

It involves the information provided in order to prolong the devices life and to be used more efficiently.

1.2- INTRODUCTORY PICTURES

All the introductory Images of your device are presented on the last pages of this guide. This guide is prepared for all models, excluding island group head fridges there are only differences in sizes for all the models.

Please examine the general view of the device on Image **A**.

1. Sliding glass lid
2. Separator
3. Handle
4. Thermostat probe
5. Protective plastic against impacts
6. External body
7. Control board
8. Stays

The parts and documents are included in the package with the device.

- User guide

1.3- PRODUCER'S AREA OF RESPONSIBILITY

The manufacturer may not be held responsible in any way for injuries and damages that may arise in case of failing to comply with the aspects stated below. The procedures performed in breach of the rules make your equipment out of warranty.

- The assembly and demonstration of the equipment must be carried out by the Authorized Service.

- The equipment has **freezer, meat and cooler** modes. Do not use the equipment for purposes other than its intended use.

- Use the equipment as specified in this manual (**Chapter 2.3**).

- Comply with the warning and safety instructions specified in the manual (**Chapter 1.1**).

- Observe the applicable safety instructions in your region.

- Use only the original spare parts provided by the manufacturer in order to maintain the safety conditions.



NOTE

Maintenance, repair and change of spare parts operations shall be carried out by Authorized People.

2- SAFETY INFORMATION AND ENVIRONMENTAL WARNINGS

2.1- BEFORE OPERATION OF THE EQUIPMENT

It is important to act in accordance with the aspects stated below before operation of the equipment with regards to safety, performance and energy consumption.



NOTE

The lubricant in the cooler part of the equipment may be displaced during transportation and transfer operations. For this reason, wait minimum 4 to 6 hours before operating the equipment.

The location of assembly of the equipment affects the performance and energy consumption of the equipment (**Chapter 3.1**). When determining the location of assembly, the Authorized Service will provide information and recommendations; however, the final decision shall be left to the user. Depending on the final decision to be given by the consumer, in case of experiencing any problem due to the location of the equipment, all responsibility shall be borne by the consumer, and the equipment shall be considered out of warranty due to problems that may emerge due to such positioning.



SUGGESTION

In order for the equipment to be used in the most efficient way, the ambient temperature where it is located must be considered. The ambient temperature in the area where the equipment will be used must be 25°C and the humidity 60% R.H.



WARNING

FIRE HAZARD

If the refrigerant gas written on the label at the back side of the equipment is R290, in case of substance leakage, make sure that the necessary ventilation has been provided in order to prevent from the mixing of the inflammable gas with air. Because the mentioned gas is environment-friendly but inflammable. In case of leakage, keep the heat sources that may lead to inflammation away from the equipment.



NOTE

The internal part of the equipment must be dry before placing products inside.

Make sure that there is air circulation in the motor part.

Please keep in mind that all electrical appliances are potential sources of hazard, and pay attention to all warnings made.



WARNING

Should be add 200-250 ml water into the drain pipe before starting the device (Image K).

****This clause applies to models containing the "DF" statement.***

2.2- TECHNICAL SAFETY

R404a or R290 refrigerant fluids are used in the manufacturing of UMD IZMIR equipment depending on the orders. You may learn what kind of cooler fluid is used in your equipment from the label at the back side of the equipment. R290 refrigerant fluid is environment friendly but inflammable. Therefore, in handling and mounting operations of the equipment, follow the steps below if the cooler or electrical equipment has been damaged.

- If there is any kind of source such as fire, sparkle etc. that may lead to in flammation at the environment where the equipment is located, keep your equipment away from such sources. Otherwise, fire, explosion, etc. may be experienced.

- Plug out the equipment and ventilate the environment where the equipment is located.

- Please contact the Authorized Service.

The refrigerant gasses in this equipment slightly increase the sound of operation of the compressor. You may hear the sound of air circulation to gether with this sound. This situation is normal and it does not affect the working performance of the equipment.

The outer frame of the equipment may get warm during operation. This situation is normal and it is caused by the design of the equipment.

2.3- DURING OPERATION OF THE EQUIPMENT

This equipment is manufactured to be used in stores such as supermarkets etc. It is important to comply with the articles stated below about the use of the equipment with regards to safety, performance and energy consumption.

- Your equipment is designed for use in indoor environments. Our company shall not be responsible due to problems that may arise in the case that you use your equipment in outdoor environments.

•The equipment can operate in **freezer, meat and cooler** mode options. Do not use the equipment for purposes other than its intended use.



WARNING
EXPLOSION HAZARD
Never use electrical appliances inside the equipment.

•In case that the equipment is used by children and people lacking knowledge (people with limited physical, emotional or cognitive skills), it may lead to some risks and dangerous situations. In order to prevent such risks, persons who may be exposed to danger must use the equipment with the guidance and under the control of the responsible person.

•Keep children younger than 8 years old away from the equipment and prevent them from using the equipment.

•Carry out the layout, installation and cleaning of the equipment as specified in this manual. As the result of applications other than specified in this manual, your equipment may be damaged and it may go out of warranty (**Chapter 3**).

•If the equipment is used in accordance with the climatic conditions for which it is designed, it will provide the best performance. This equipment is designed to be used in

indoor environments. According to EN 23953-2, it must be used in environments to provide Climate Class 3 (25°C– 60% R.H.).

2.4– WASTE DISPOSAL

This equipment is compatible with **Waste Electrical and Electronic Equipment (WEEE) Control Regulations**. Within the scope of this regulation, it may be recycled by **Licensed Companies** or may be disposed of under conditions consonant with the environment.

This equipment is not an invaluable waste. You may protect the environment and natural resources by enabling reuse of valuable raw materials. If the equipment is worn and may not be reused, please follow the steps below.

•Plug out the equipment.

•Cut the equipment's electric cable and separate it from the equipment together with the plug.

•Get information about the **Waste Electrical and Electronic Equipment (WEEE)** collecting points or the **Licensed Companies** from your municipality.

3- INSTALLATION

3.1- SELECTION OF DEVICE PLACE

The working environment is very significant in order for the device to work smoothly. Ensure that the conditions stated below are provided with regards to the place the device will be installed in for the cooling performance and energy consumption to stay within the proper values.

- A bowless, flat and solid ground shall be chosen for the device.

- The size of the room where the equipment will be used must be 1 m³ for each 8g of refrigerant. The amount of refrigerant that your equipment contains is written on the label on the bottom left part back of cabin (**Image J**).

- The ventilating slits of the device shall not be covered. There shall be at least 150 mm distance between the device's ventilating slits and the wall.

- There shall be a grounded and solid plug present close to the device.

- Device shall be placed at least 1 meter away from heat sources (oven, cooker, stove, radiator etc.)

- Device shall be placed where there is no direct sunlight.

- Device shall be placed away from places where there is air stream (against the air condition openings, under fans, at doorsteps or close to windows etc.).



SUGGESTION

Comply with the Authorized Persons guidance and suggestions for place selection in order to get the best performance from the device.

3.2- TAKING OUT OF PACKAGE

Do not use sharp/piercing materials to open the package. Take the device out of the package by taking the warnings, which are prepared suitable to all package materials, stated below into consideration.

Dismantle the cable ties around the package and take the cardboard package off the device. Take out the styrofoam materials that are at the top and on the side of the device.

Dismantle the tie, which is under the device and attached with pallet, in order to take the device off the pallet. Get in front of the device as shown in **Image B** push the device backwards by applying force.

**NOTE**

Packaging materials may be dangerous for children. Preserve the packaging materials in a place where children cannot reach. Packaging materials are suitable for recycling and may be reused. Thus, dispose of the package materials in accordance with waste disposal instructions or by consulting to your municipality and in a way that will not damage environment.

3.3- INSTALLATION

3.3.1- ADJUSTMENT OF ADJUSTABLE STAYS

Balance the device by way of a water gauge with regards to the width and length. You may carry out the balancing with the help of the stays on the device. You may adjust the balance with the help of a key because of the device's weight. As is shown in Image **G** it may be adjusted to a level you desire and you may raise it to 13 mm in maximum. Wear protective gloves while carry out the balancing operation.

3.3.2- MULTIPLE DEVICE USE LAY-OUT POSITIONS

3.3.2.1- STAND ALONE USE

Pay attention that there is at least 150 mm distance between the wall and the device (back part). The device may have a contact with the wall on the side. A visual regarding the device's lay-out is presented on Image **D**.

3.3.2.2- SINGLE LINE ARRAY

Pay attention that there is at least 150 mm distance between the wall and the device (back part). In case you will line up more than one market fridge side by side, it is not necessary to leave an air gap between them. A visual regarding the device's lay-out is presented on Image **E**.

3.3.2.3- SUCCESSIVE ARRAY

In case you will place more than one market devices back to back, you shall definitely use special profiles and lids. Thus, by means of the profiles and lids, there will be at least 150 mm distance between two back-to-back market devices. A visual regarding the device's lay-out is presented on Image **F**.

*You may all the necessary original spare parts and island assembling guide from Authorized People.

3.3.2.4- HEAD FRIDGE AND ISLAND ARRAY

It is the island group consisting of head fridges, which are placed at the head of the group, in addition to the back-to-back array. It is not necessary to leave air gaps between head fridges and other fridges. A visual regarding the device's lay-out is presented on Image **G**

- Extension cables or multi-plugs shall not be used.

- Damaged electric cable shall be replaced by a professional electricity expert.

- A grounded socket, which is protected by a fuse with sufficient capacity (that has 10-16 A strength), shall be used for the device.

- In case there is an electrical problem with the device, the device shall not be used until it is repaired. Electric shock may occur.



WARNING

FIRE HAZARD

you definitely shall leave the ventilating slits and surroundings open within the scope of the rules stated on the guide. Definitely do not prevent air flow. Definitely do not cover.

3.4- ELECTRICAL CONNECTIONS

EN

This device works with 220-240V/ 50-60 Hz, 110-127/60 Hz alternating current. Check this value from the label at the back of the device (**Image J**). The aspects you shall pay attention to while using the device are stated below:

- The plug shall be easily accessed also after the device is placed.

- Signified voltage shall be equivalent to grid voltage.

4- DEVICE USAGE

4.1- THERMOSTAT ADJUSTMENTS (EWPLUS 978)

4.1.1- GENERAL INFORMATION AND INSTRUCTIONS

The explanations regarding the symbols on the thermostat and general information about the settings are given below.





When the device starts working, check whether screen and light are working or not.

Thermostat visual is presented on Image .





Keys;

1- []/Defrost: Press and release, increases the sliding values between Menu options or enables transition. When you press it at least for 5 seconds, Manuel Defrost Loop starts.

2- []/Light: internal menu status, decreases the sliding values between menu options or enables transition. When you press it at least for 5 seconds, the light turns on/off.

3- []/(Esc): Press and release, enables to return to the previous menu level and to approve parameter value. When you press it at least 5 seconds, opens the programming menu. Approves the commands (Standby on).

4- []/(Enter) : Press and release, shows alarms and opens sub menus (if any). Approves the commands.

	<p>Reduced SET / Economy LED Permanently on: Energy Saving active Flashing: Reduced set active Quick flashing: Access to level2 parameters Off: Otherwise</p>		<p>Fans LED Permanently on: Fans active Off: Otherwise</p>
	<p>Compressor LED Permanently on: Compressor active Flashing: Delay, protection or activation blocked Off: Otherwise</p>		<p>Defrost LED Permanently on: Defrost active Flashing: Activated manually or from DI Off: Otherwise</p>
<p>AUX</p>	<p>Aux LED Permanently on: Aux output active Flashing: Deep cooling Cycle active Off: Aux output not active</p>		<p>Alarms LED Permanently on: alarm active Flashing: alarm acknowledged Off: otherwise</p>
<p>°C</p>	<p>°C LED Permanently on: °C setting (dro = 0) Off: otherwise</p>	<p>°F</p>	<p>°F LED Permanently on: °F setting (dro = 1) Off: otherwise</p>

Digital thermostats contain many parameters within themselves. Your thermostat has factory settings by default and does not require any adjustment, however, the user has the option to change the mode on EWPlus 978 thermostat. EWPlus 978 thermostat may operate in three different modes.

1. Freezer (-18 / - 23 °C)
2. Meat Mode (-2 / +2 °C)
3. Cooler (-1 / +5 °C)

You may change the mode according to the instructions below:

- Press the key [ⓘ] for 5 seconds while the equipment runs. You will see the word "OFF" on the screen and the equipment will turn off all functions except of lighting.
- Press and hold the key [ⓘ] for another 5 seconds. The equipment will switch to "ON" position. The compressor symbol will be seen on the screen.
- Press and hold the key [ⓘ] for 5 seconds again within 15 seconds. (If no operation is done within this period, the mode change will be cancelled.) "AP1" will be seen on the screen.
- AP1-AP2-AP3 modes can be seen with the keys [↕]/[↘]. Press key [SET] once when the mode you want to choose is on the screen. The letter "y" will be seen on the screen and the desired mode will be selected.
- The modes that you may select are as in the table below.

Example : In case the mode you want to choose is Meat mode, then when you press [SET] key when AP2 is written on the screen, then you switch to Meat mode.

AP1	AP2	AP3
Freezer Mode -18/-23 °C	Meat Mode -2 / +2 °C	Cooler Mode -1 / +5 °C



In case you think that there is a problem with regards to the operation of the device or with regards to digital thermostat settings, please ask for support from the Authorized Person.

4.1.2- SET TEMPERATURE

To display the Setpoint value press the [SET] key when the 'SEt' label is displayed. The Setpoint value appears on the display. Please again press the [SET]. To change the Setpoint value, press the [↕] and [↘] keys within 15 seconds. Press [SET] to confirm the modification. Press the [ⓘ] key to exit setting.

4.1.3- AUTOMATIC DEFROST

Automatic defrost is available for DF models. The device is programmed to defrost automatically in accordance with the mode the device is working. There will be some frost deposit while the device is working due to the humidity of the environment. Because of defrost, the generated frost deposit will be melt and the device will work with maximum productivity. Defrost ranges in accordance with the modes are presented on the table below.

Cooler Mode: 12 Hours

Freezer Mode: 24 Hours

Et(Meat)Modu: 12 Hours

4.1.4- MANUAL DEFROST

Hold down the []key for longer than 5 seconds. It is only activated if the temperature conditions are fulfilled. Otherwise, the display will blink 3 times to indicate that the operation will not be performed.





4.2- THERMOSTAT ADJUSTMENTS (EWPLUS 971)







EWPlus 971 thermostat is used for D (freezer without defrost) models.

4.2.1- GENERAL INFORMATION AND INSTRUCTIONS

Thermostat visual is presented on Image .

Keys;







- 1- []: Press and release, increases the sliding options among menu options and enables transition.
- 2- []/Light: Internal menu status, reduces sliding values among menu options or enables transition. When you press for 5 seconds, the Light turns on/off.
- 3- []/(Esc): Press and release, return to the previous menu and approval of parameter values. When you press at least for 5 seconds, all the functions are turned off excluding the lights (Standby on)
- 4- []/(Enter): Press and release, displays the alarms and opens sub menus (if any). When you press for 5 seconds, opens programming menus. Approves the commands.

	Reduced SET / Economy LED Permanently on: Energy Saving active Flashing: Reduced set active Quick flashing: Access to level2 parameters Off: Otherwise		Fans LED Permanently on: Fans active Off: Otherwise
	Compressor LED Permanently on: Compressor active Flashing: Delay, protection or activation blocked Off: Otherwise		Alarms LED Permanently on: alarm active Flashing: alarm acknowledged Off: otherwise
AUX	Aux LED Permanently on: Aux output active Flashing: Deep cooling Cycle active Off: Aux output not active		°F LED Permanently on: °F setting (dro = 1) Off: otherwise
	°C LED Permanently on: °C setting (dro = 0) Off: otherwise		

 **NOTE**

Your thermostat is set on factory defaults and does not requires any adjustment. Only freezer without defrost mode is available for EWPlus 971 thermostat.

4.2.2- SET TEMPERATURE

To display the Setpoint value press the  key when the 'SET' label is displayed. The Setpoint value appears on the display. Please again press the . To change the Setpoint value, press the  and  keys within 15 seconds. Press  to confirm the modification. Press the  key to exit setting.

4.3- THERMOSTAT ADJUSTMENTS (AKCC 210)

4.3.1-GENERAL INFORMATION AND INSTRUCTIONS

Thermostat visual is presented on **Image H2**.

Keys;

1-Short press, acknowledge alarms or see control status. Long press, setup menu.

2-Press, change temperature set point

3-Short press, see defrost sensor temperature. Long press, start a defrost cycle.

4.3.2-SET TEMPERATURE

- Push the middle button until the temperature value is shown.

- Push the upper or the lower button and select the new value.

- Push the middle button again to conclude the setting.

4.3.3-MANUAL DEFROST

Reading the temperature at defrost sensor.

- Push short the lower button.

Manuel start or stop of a defrost.

- Push the lower button for four seconds.

4.3.4-CUTOUT ALARM RELAY/RECEIPT ALARM/SEE ALARM CODE

- Push short the upper button.

If there are several alarm codes they are found in a rolling stack. Push the uppermost or lowermost button to scan the rolling stack.

4.4- THERMOSTAT ADJUSTMENTS

4.4.1-GENERAL INFORMATION AND INSTRUCTIONS

The explanations regarding the sybols on the thermostat and general informtion about the settings are given below.

Thermostat visual is presented on **Image H4**.

1) [P] : Parameter Key

2) [▲] : Up Key

3) [▼] : Down Key

4) [🔥] Status LED: Defrosting

5) [❄️] Status LED: Cooling

6) [🌀] Status LED: Fan

7) [8888] : Display

8) [●] LED: Settings mode enabled

9) [●] LED: Expert settings

4.4.2-SET TEMPERATURE

Push the 3 buttons [P▲] Press [P] key for 5 seconds. The "Settings mode enabled" LED flashes. Push [P]. Push the 2 buttons [P▼ or P▲]. The display show must be ^P2^. Then set you want operating temperature value with only button [▲/▼]. Again push [P].

4.4.3-MANUAL DEFROST

Push the 3 buttons [P▲] Press [P] key for 5 seconds. The "Settings mode enabled" LED flashes. Push [P]. Push the 2 buttons [P▼ or P▲]. The display show must be ^P9^. Then set 'ON' only button [▲/▼]. When defrost is over, the device will automatically return to normal operation.

4.5- THERMOSTAT ADJUSTMENTS (ERC 112D)



4.5.1-GENERAL INFORMATION AND INSTRUCTIONS

The explanations regarding the symbols on the thermostat and general information about the settings are given below.

Thermostat visual is presented on **Image H3**.

- 1) [] : Defrost Key
- 2) [] : Stand by Key
- 3) [] : Up Key
- 4) [] : Down Key

4.5.2-GENERAL INFORMATION AND INSTRUCTIONS

Push the [] until the temperature value is shown or push the [] until the temperature value is shown.

4.5.3-MANUAL DEFROST

Manual start or stop of a defrost.

- Push the [].

5- SPECIAL INSTRUCTIONS FOR USE

Perform the external cleaning of your equipment with cotton cloth and warm water. Prevent the cleaning water from penetrating into the lighting parts of the equipment during cleaning.

- Clean the cover seal only by using clean soapy water. The plastic components of your equipment might get damaged due to cleaning with chemical cleaners (such as thinner, etc.).

- Always keep the lid seals (gasket) located on the edges of the lids clean, in case there is any damage on the seals, you may call Authorized People.

- In order not to clogging the water outlet of the device, this outlet channel should always be cleaned from dirt. The residues around this hole should be cleaned at regular intervals.

5.1- DEFROSTING

In case the internal walls of the device is excessively frosted, this condition will lead to the decrease of the cooling capacity and to consumption of more energy. Clean the frosted places with the shaving knife supplied with the device, without damaging the walls. In case frosting is too much, place the products inside the device in an appropriate place where they will not be ruined. Then, plug out the device. Normally, the frosting shall be melted within two (2) hours. After the melting process, wipe the internal wall of the device with a dry cloth and pay attention that it does not stay wet. Operate your device as hollow until "-18" appears on your thermostat screen. When "-18" appears on the screen, you can upload your products. If there is your device model name containing 'DF', see sections titled "Manual Defrost".

5.2- GLASS CLEANING

Attention must be paid especially to the aspects stated below concerning the glass surface of UMD IZMIR equipment, which is plated, located inside and which has high heat reflection feature and has low emission level (Low-E);

- The cleaning of the plated part inside the equipment must be made when the equipment is off.

- Hard or sharp objects made of metal (glass scraper, glass knife, steel wool etc.) that may damage the glass surfaces must not be used.

- Make sure that the glass surfaces to be cleaned are exposed to too much water and that they are thoroughly dried after surface cleaning.

WARNING
ELECTRIC SHOCK
Never wash this equipment.

5.3- GLASS CLEANING

For decreasing the energy consumption;

- Do not place hot food inside the equipment.

- Do not keep the cover of the equipment open for a long time.

- The equipment must be placed at a location where there is no direct sunlight.

- For discharging the heating inside the part where the cooling components of the equipment are located, the screens covering the cooling group must not be covered with an object. Otherwise, the cooling process of the equipment extends and the energy consumption increases.

- If you think that there is frost deposit in your equipment, please perform defrosting operation (**Chapter 5.1**).

- Leaving the cover of the equipment may cause frost deposit inside the equipment. In order to prevent frost deposit, when you do continuous loading, perform manual defrosting operation on your equipment after the loading (**Chapter 5.1**).

5.4- LOADING CAPACITY

- Make sure that the foods loaded in the equipment are below the loading line (**Image 0**).

- Do not place products in the equipment before reaching the sufficient storage coolness.

- Products placed in the equipment in unpacked condition or in nylon bags with holes might cause fluid leakage. The leaking fluid might cause problems such as corrosion, staining and cracking on the plastic parts, losing the hygiene conditions inside the equipment, formation of odour, reproduction of bacteria, etc.

- When you do continuous loading, perform manual defrosting operation on your equipment after the loading (**Chapter 5.1**).

6- TURNING OFF AND CARRYING THE DEVICE

6.1- TURNING OFF THE DEVICE

If will not use the equipment for a long time due to reasons such as vacation, travels etc., pay attention to the articles stated below.

Turn off the device. To turn off the device,

Press the [ⓘ] button for 5 seconds. "OFF" will appear on the screen. (Applies to devices with one of the EWPlus 971/EWPlus 978 thermostats.) If you have ERC 112D thermostat press the [ⓘ] button.

- Empty the foods out of the equipment, dry the interior part of the equipment properly, and leave the cover open.

- Do not cover the equipment with materials such as plastic coatings etc.

6.2- CARRYING THE DEVICE

Empty the foods out of the device, dry the interior part of the device properly and leave the lid open.

- Turn off the device (**Chapter 6.1**).
- Carry the device under normal usage position. Do not carry the device in sidewise, vertical, oblique positions or when the lid is open.
- Protect the device from impacts while carrying. Do not carry the device when it is plugged in or when full.
- Carry and store the device as stated on the package.
- In order to prevent the device to fall or slide and fall, you shall fasten the device during transportation.

NOTE

If the plastic parts inside the equipment do not let the air in, it may lead to odour, mould growth due to humidity and perspiration. Perspiration may lead to corrosion on the metal parts.

7- TURNING OFF AND CARRYING THE DEVICE

In case you encounter the problems stated below, please check whether you can solve the problem by yourself or not before contacting the Authorized People. In case the problem exceeds your boundaries of authority, please call the Authorized people.

MALFUNCTION	POSSIBLE REASON	SOLUTION
Device is not working and none of the displays are on.	Plug is not fitted appropriately to the socket.	Check whether the plug is plugged to the socket or not and whether there is electricity or not.
	There is no electricity on the socket or there has been a blown-out.	
	There is damage on the operating cable or on the socket.	Immediately turn off the fuse and plug out the device. Contact with the Authorized Person for the replacement of the cable of the device. Appeal for help of qualified electrical expert for the socket control.
Compressor is always working.	The lids of the device is frequently opening and closing or the lid of the device is left open.	Do not open and close the lid of the device unless necessary, and keep the lid of the device closed.
Device is not freezing/cooling	The lid is left open.	Check the lid of the device. Abolish all the aspects that prevent the closure.
	Too many products are placed.	Pay attention to loading line. Place the products as not to exceed this line limit (Image 0).
	Ventilating slits are closed	Remove the objects around the device. Keep the necessary distance.
	There is a heat source close to the device.	Keep the heat sources away from the device.
	Thermostat is malfunctioned	In case the thermostat indicator is flashing, contact with the Authorized Person.

Internal lightning is not working.	LED is malfunctioned	Get in contact with the Authorized Person.
Device is making too much noise.	The stays of the device are not balanced.	Control the accuracy of the operation of 3.3.1 (Image G) .
	Device is in contact with another object.	Disconnect the device from the object that may vibrate.
	Engine fan is in contact with another object.	Immediately call the Authorized People.
Device is giving off odor.	Improper product placement.	The products to be placed inside the device shall be used in accordance with Freezer/Meat/Cooler modes.
	There is a problem in packaging of the product inside the device.	Do not place the products whose packages are damaged inside the device.
Water is leaking on the engine part.	There is damage the evaporation cup.	Call the Authorized People and ensure that the damaged evaporation cup is replaced.
	There may be a crack on the evacuation pipe or the evacuation pipe may be dislocated.	Call the Authorized People and ensure that necessary operation is carried out.
Frost formation on the side of the device	The lid of the device is opened too frequently.	Do not open and close the lid of the device excluding the necessities and keep the lid of the device closed.

NOTE

The device will make some sounds while working. These sounds may be normal. Check the table below.

Device Operating Sounds	
Humming sound	Cooler system is working.
Babbling, rustling sounds	Cooling gas is passing through pipes.
Clicking	Compressor is being activated and deactivated.
Clicking when the device is turned on	Interior lighting switch is on.

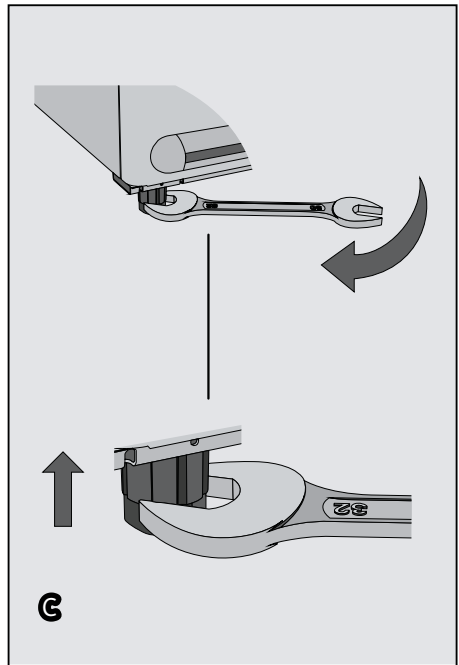
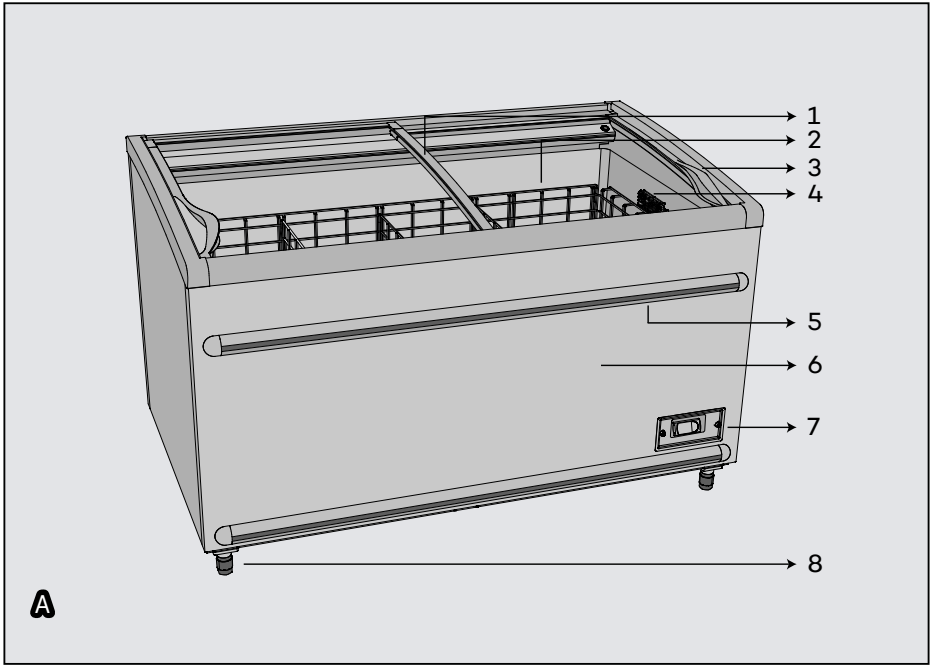

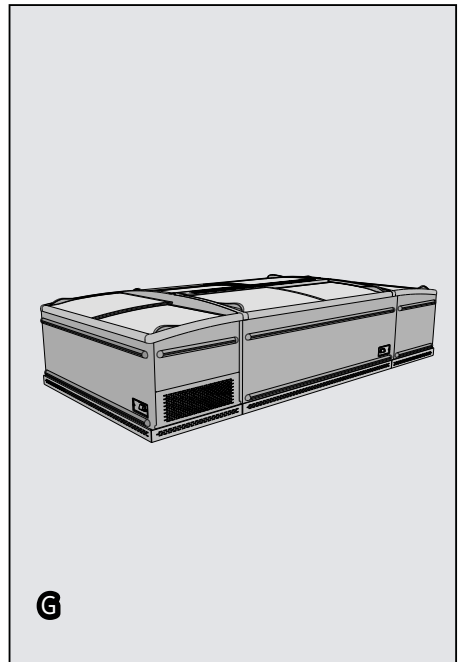
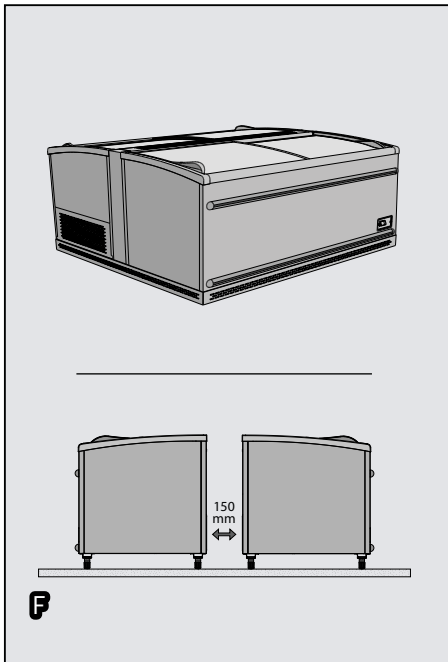
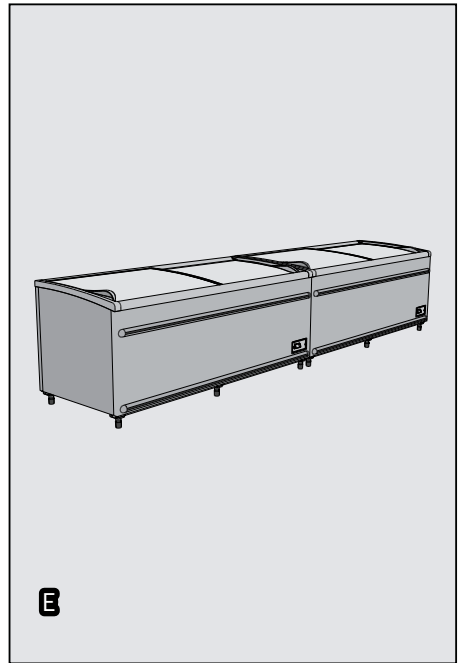
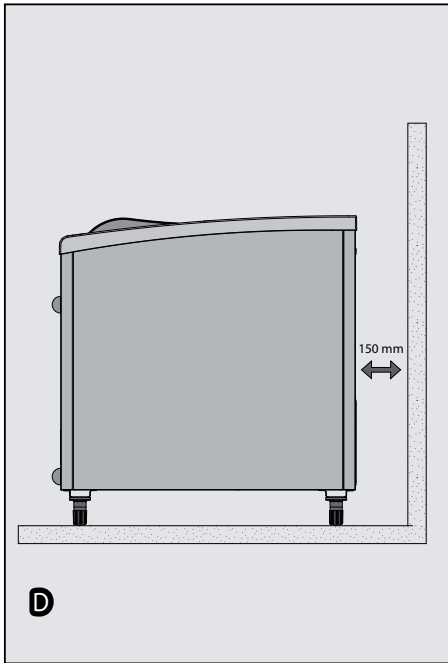

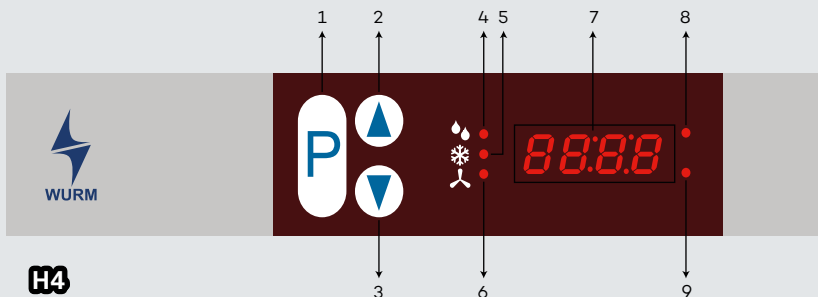
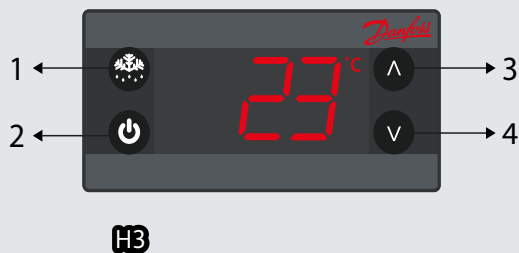
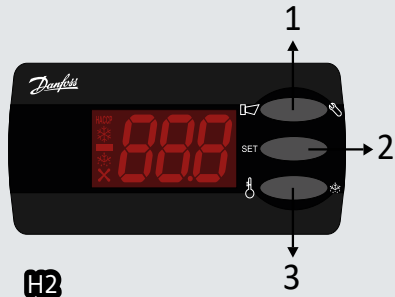
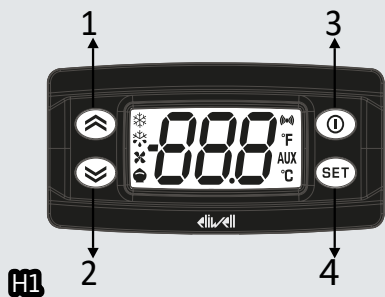

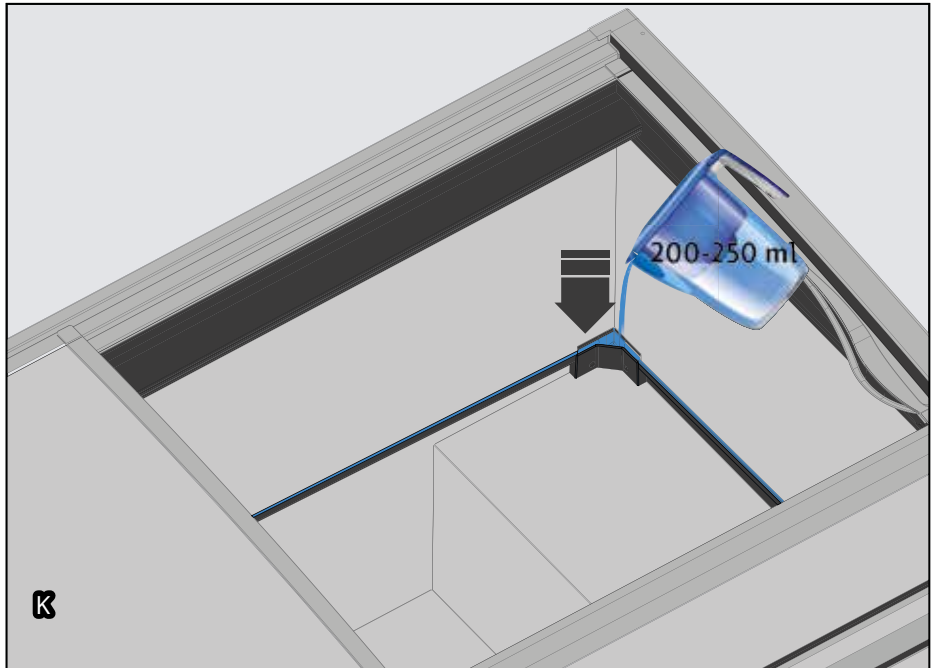
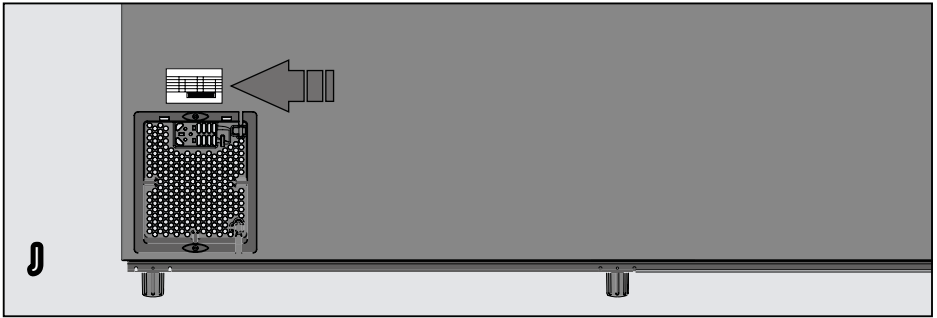
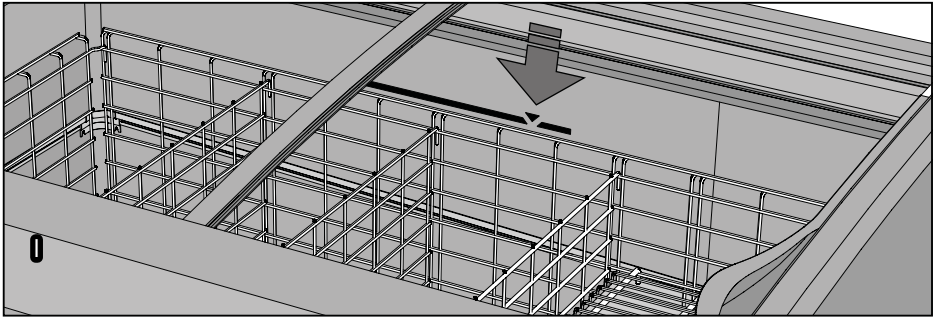

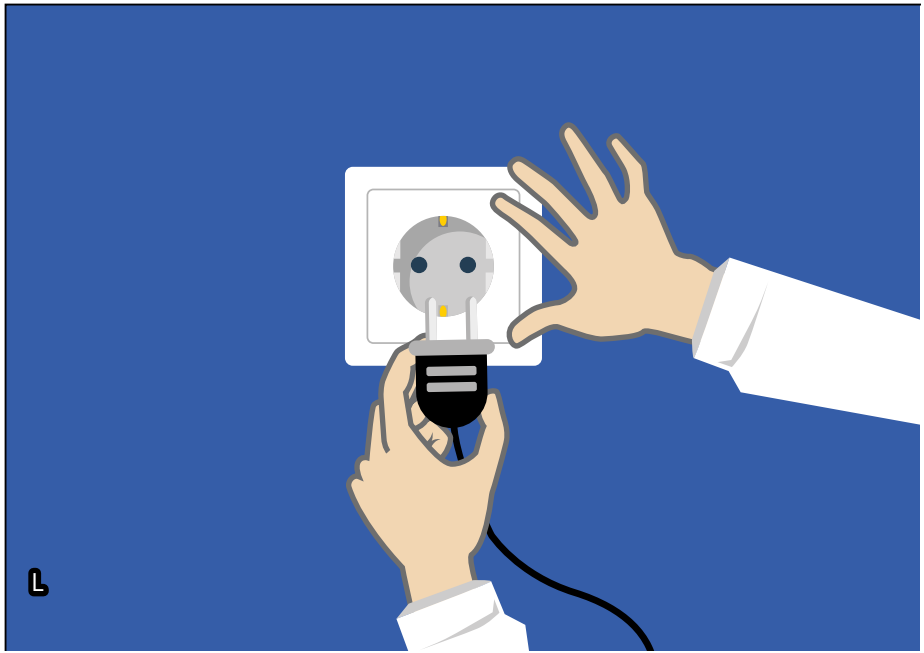



Uğur Soğutma Makinaları Sanayi ve Ticaret A.Ş.

Head Office

Yeni Sanayi Mahallesi
Devlet Kara Yolu Caddesi No: 127/C
Nazilli/AYDIN TÜRKİYE
T: 0.256 316 10 00
F: 0.256 316 10 31
ugur@ugur.com.tr

Marmara Region Headquarters

Mahmutbey Mahallesi 2534 Sokak No: 9A
Bağcılar/İSTANBUL TÜRKİYE
T: 0.212 624 32 28
F: 0.212 541 96 36
istanbul@ugur.com.tr

A1304000400

www.ugur.com

